

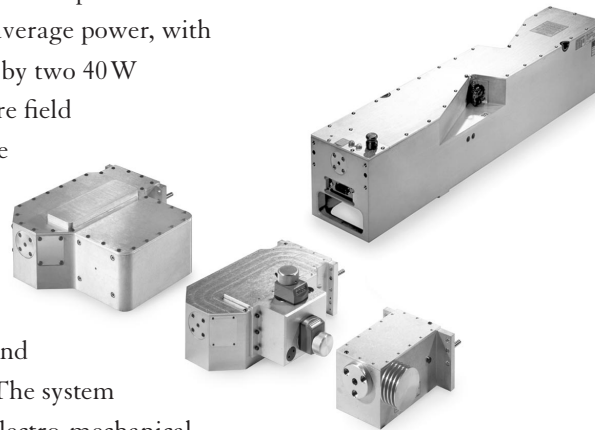

Navigator II YHP40 OEM Laser System 1064, 532, 355, and 266 nm

The Navigator II YHP40 is an advanced diode pumped solid state laser system. Its Q-switched output characteristics have been optimized for applications requiring high peak power and high average power, with superior pulse stability. The laser head is pumped by two 40 W ProLite™ modules. These unique pump sources are field replaceable, requiring no optical realignment of the laser head. The laser head is manufactured in a clean room environment and sealed to prevent optical contamination. The standard system includes an electro-mechanical shutter and power monitor. Second (532 nm), third (355 nm), and fourth (266 nm) harmonic modules are available. The system includes a compact, solid state chiller, an internal electro-mechanical shutter and power monitor.



Applications include, but not limited to, laser marking, scribing, stereolithography, and materials processing.

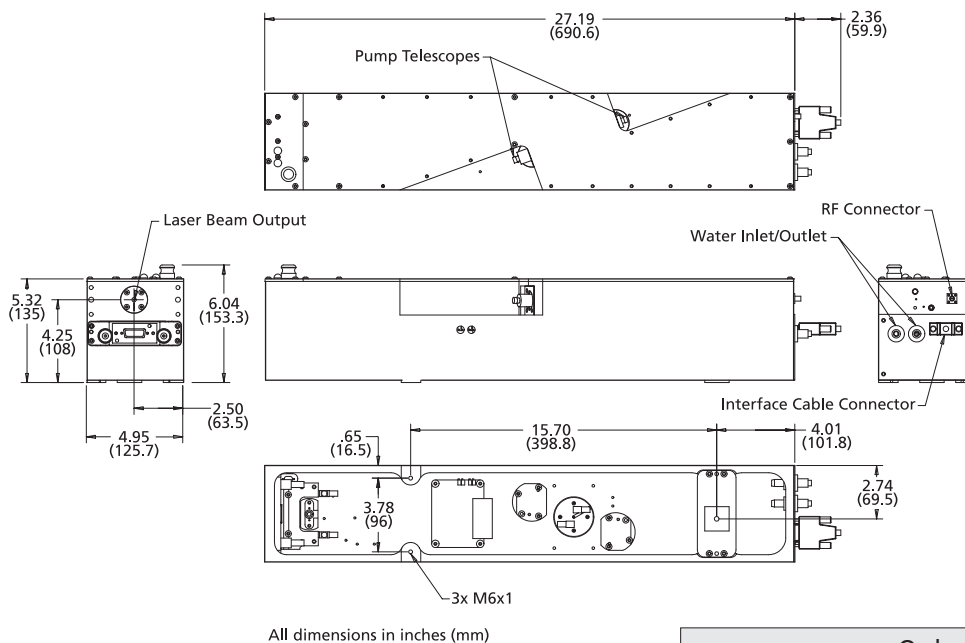

Ordering Information

Ordering Information	
J80-YHP40-106QW	J-Series system, 1064 nm
J80-YHP40-532QW	J-Series system, 532 nm
J80-YHP40-355QW	J-Series system, 355 nm, manual translation
J80-YHP40-355QWA	J-Series system, 355 nm, automatic translation
J80-YHP40-266Q	J-Series system, 266 nm, automatic translation

YHP40-532QW Line Drawing

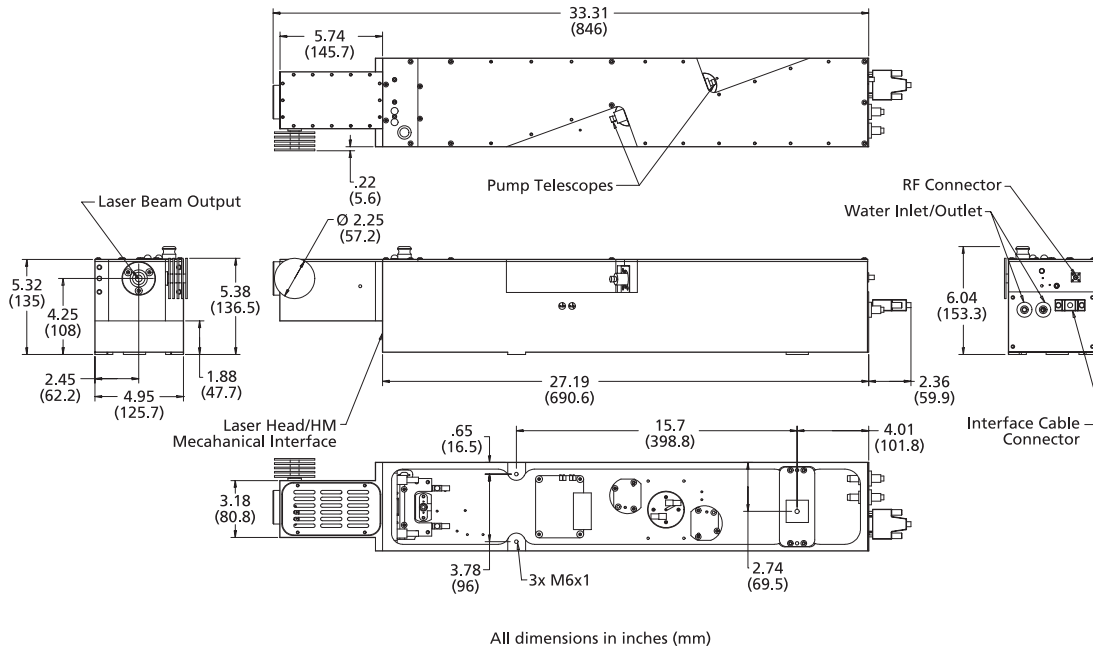

YHP40-355QW Manual Line Drawing

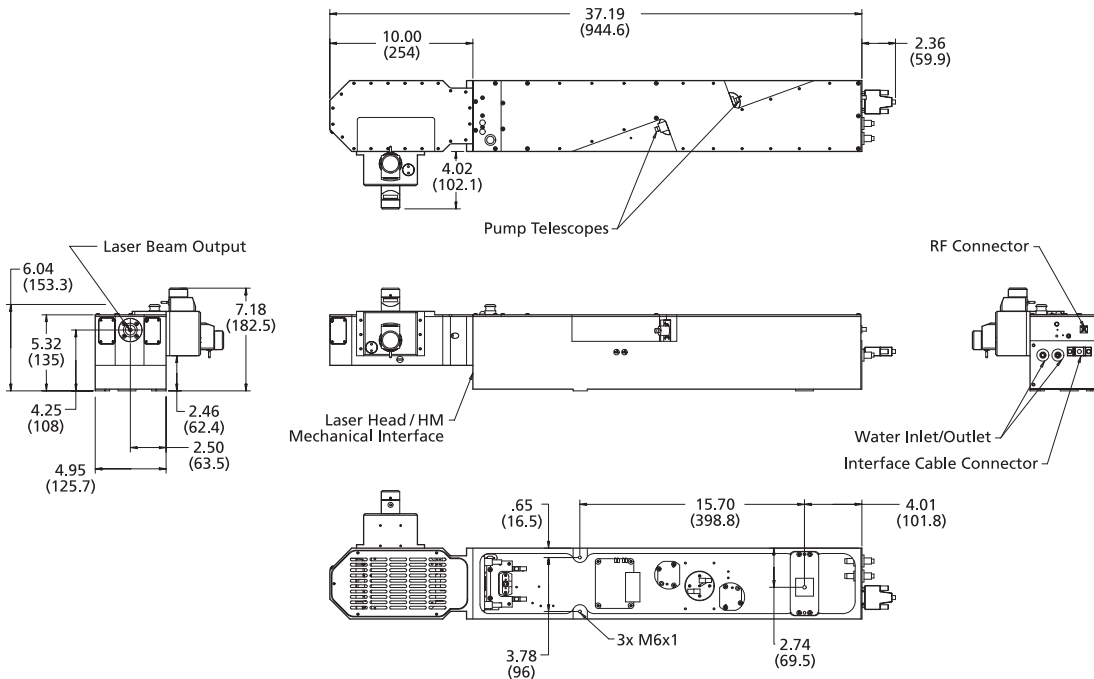

YHP40-355QWA and YHP40-266Q Automatic Line Drawing

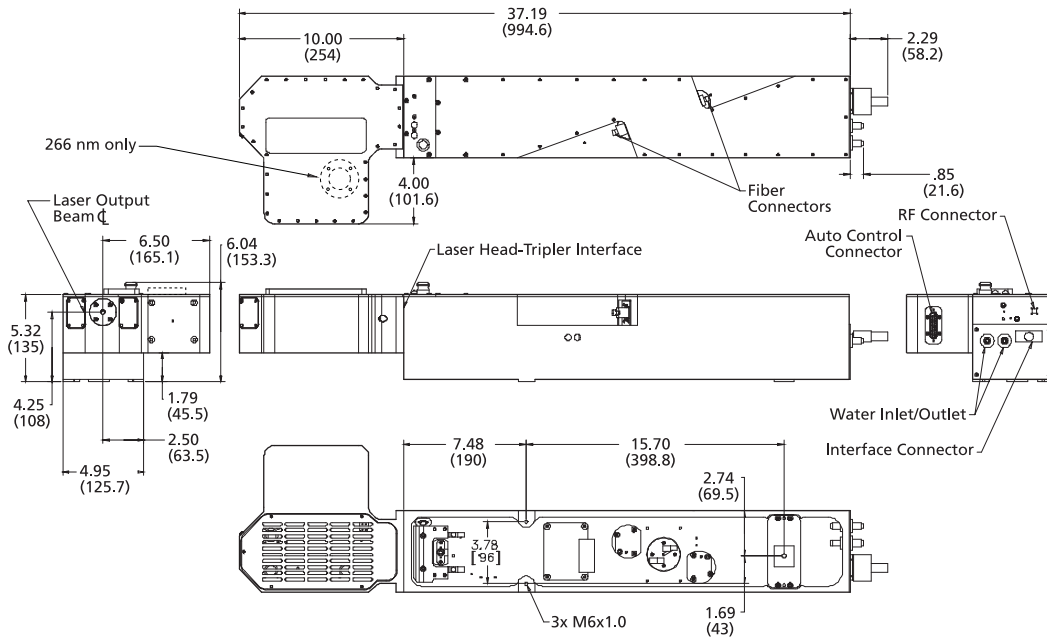

All dimensions in inches (mm)

J80 Power Supply Line Drawing

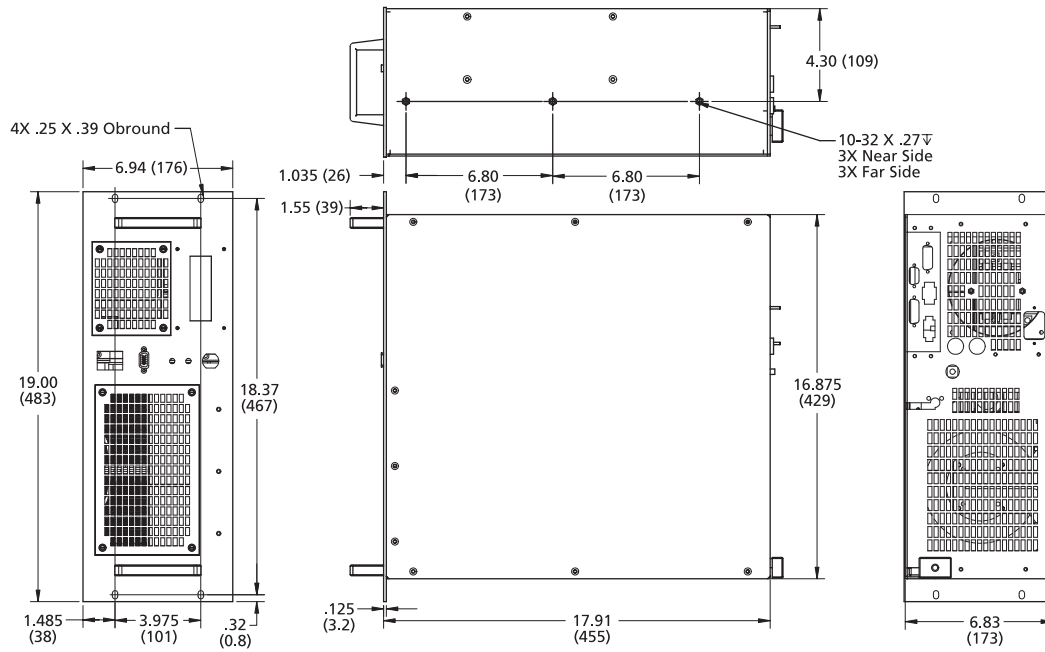

All dimension in inches (mm)

Navigator II YHP40 OEM Laser System Specifications

Performance Characteristics

General Characteristics ^{1,2}				
Wavelength	1064 nm	532 nm	355 nm	266 nm
Power	15 W at 20 kHz 18 W at 80 kHz	9 W at 20 kHz	3.5 W at 20 kHz	1.5 W at 20 kHz
Repetition rate range, kHz	15 to 100	15 to 100	15 to 100	15 to 80
Pulsewidth, nominal	40 nsec @ 20 kHz 70 nsec @ 80 kHz	35 nsec at 20 kHz	35 nsec at 20 kHz	30 nsec at 20 kHz

Beam Characteristics ²				
Spatial mode	TEM ₀₀	TEM ₀₀	TEM ₀₀	TEM ₀₀
M ²	< 1.15	< 1.2	< 1.5	< 1.5
Polarization	100:1, vertical	100:1, horizontal	100:1, vertical	100:1, vertical
Beam diameter (at waist)	0.65 mm nominal	0.85 mm nominal	1 mm nominal	1 mm nominal
Waist Location	-17cm nominal from output face	-10cm nominal from output face	1.5m nominal from output face	-50 cm nominal from output face
Beam divergence, full angle	2.3 mrad nominal	0.7 mrad nominal	0.6 mrad nominal	0.5 mrad nominal
Beam ellipticity	< 10%	≤ 10%	≤ 20%	≤ 20%
Boresight	± 0.2 mm position at output ± 0.5 mrad angle		± 0.2 mm position at output ± 0.5 mrad angle	± 0.2 mm position at output ± 0.5 mrad angle

Stability ^{2,3}				
Beam pointing	< 20 microradians per °C	≤ 20 microradians per °C	≤ 20 microradians per °C	≤ 20 microradians per °C
Pulse-to-pulse stability	< 1.5% rms @ 20 kHz	< 3% rms at 20 kHz	< 3% rms at 20 kHz	< 6.5% rms @ 20 kHz

Notes:

1. Due to our continuous product improvement program, all specifications are subject to change without notice.
2. All specifications at 20 kHz PRF unless otherwise noted.
3. Stability measurements made over ± 2°C dynamic range within specified operating range.
4. This data applies only to the laser head. Refer to power supply data sheets for more information.

Environmental & Physical Characteristics

Environmental Characteristics ⁴				
Operating Conditions				
Warm-up time	< 20 minutes from cold start	< 20 minutes from cold start	< 30 minutes from cold start	< 30 minutes from cold start
Temperature range	18°C - 35°C	18°C - 35°C	18°C - 35°C	18°C - 35°C
Altitude	0 - 3,000 meters	0 - 3,000 meters	0 - 3,000 meters	0 - 3,000 meters
Humidity	8 - 95%, non-condensing	8 - 90%, non-condensing	8 - 90%, non-condensing	8 - 90%, non-condensing
Nonoperating Conditions				
Temperature range	0°C - 50°C	0°C - 50°C	0°C - 50°C	0°C - 50°C
Altitude	0 - 12,000 meters	0 - 12,000 meters	0 - 12,000 meters	0 - 12,000 meters
Humidity	8 - 95%, non-condensing	8 - 95%, non-condensing	8 - 95%, non-condensing	8 - 95%, non-condensing

Physical Characteristics				
Weight (laser head) ⁴	9.1 kg (20 lbs)	11 kg (24 lbs)	15.1 kg (33 lbs)	14.9 kg (33 lbs)

J80-YHP40-106QW Typical Performance Data

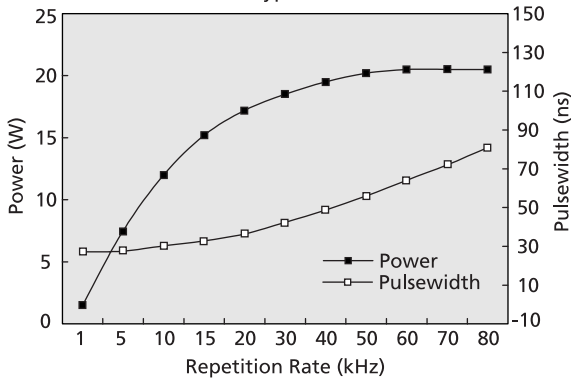

J80-YHP40-532QW Typical Performance Data

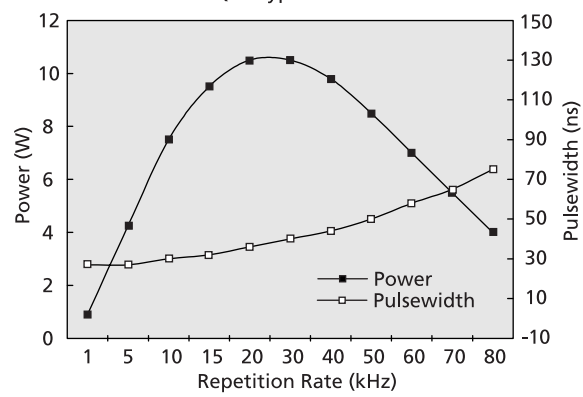

J80-YHP40-355QW Typical Performance Data

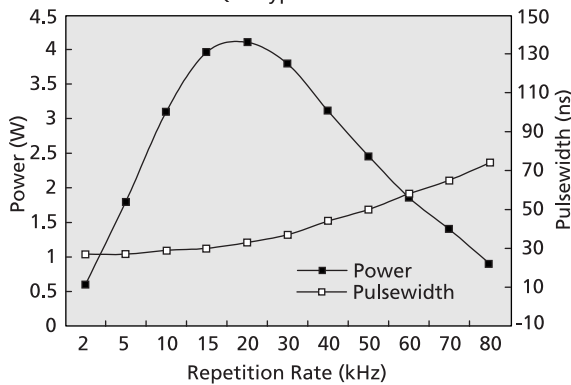

J80-YHP40-266Q Typical Performance Data

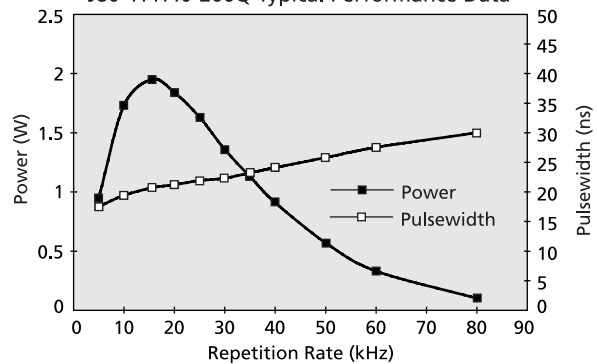

Notice

The Navigator II laser systems comply with Title 21 of the United States Code of Federal Regulations, Chapter 1, Subchapter J, Parts 1040.10 and 1040.11, as applicable.

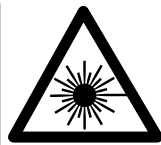
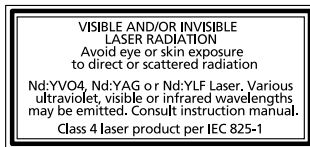

ISO 9001 Certified

Warranty

Spectra-Physics' Navigator II YHP40 laser system is protected by a 12 month warranty. All components and assemblies are unconditionally warranted to be free of defects in workmanship and materials for the warranty period, beginning from the date of shipment. This warranty is in lieu of all other warranties, expressed or implied, and does not cover incidental or consequential loss. This warranty does not apply to devices damaged due to operating conditions outside of the specified parameters. Modified warranties for OEM customers are available.



Corporate Headquarters

1335 Terra Bella Avenue
 Mountain View, CA 94043
 Tel: 1-800-SPL-LASER (775-5273)
 Tel: (650) 961-2550
 Fax: (650) 964-3584
 E-mail: sales@splasers.com
 www.spectra-physics.com